



# Ward Leonard

Excellence in Motor and Control Solutions™

## 400 HP AC Drilling Motor – WL250040



### For Top Drive Applications

### Benchmark Performance for Oil & Gas Applications

In the oil and gas industries, motors must have optimal performance, reliability and long-life to withstand the most demanding environments. The 400 HP Drilling Motor was designed to endure rigorous high shock and vibration conditions for decades of continuous service in the harshest rig duty environments. The motor features a certified Class H - fully taped and sealed - insulation system that provides a solid barrier to dust, sand, oil and water and helps to extend the life of the motor.

#### Standard Features

- ◆ 4 pole stator
- ◆ Cast aluminum rotor bars
- ◆ Certified Class H insulation
  - Fully taped with silicon tape
  - Glass sleeving on bolted wire connections
  - Fully vacuum impregnated
  - Tested for 4 hours under water at 500 V
- ◆ 4140 and 4340 alloy shafts available
- ◆ Six 100Ω platinum RTDs; 2/phase embedded in stator

- ◆ Shaft seals and oil slingers on the drive and non-drive sides
- ◆ Designed for Variable Frequency Drive operation
- ◆ Designed for high shock environments
- ◆ Heater
- ◆ IP 44 motor enclosure
- ◆ ISO 9001:2008-certified
- ◆ ATEX and CSA-approved

#### Optional Features

- ◆ Encoder
- ◆ Bearing RTD
- ◆ Blower assembly
- ◆ Air pressure switch
- ◆ IP 56 junction box
- ◆ ABS certification



# 400 HP AC Drilling Motor



## Speed - Torque Performance That Leads the Industry

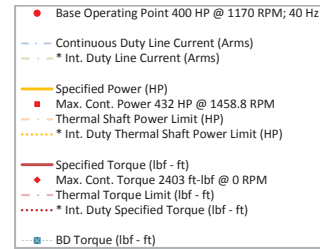
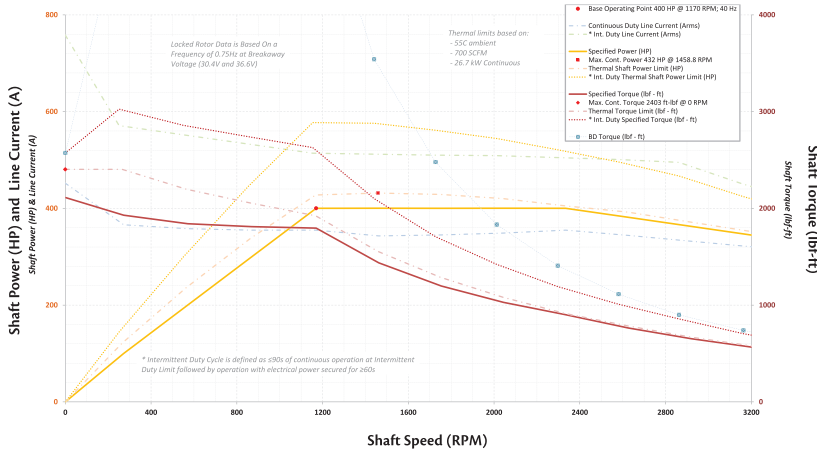

## Critical Data

Model number	WL250040
Voltage (AC)	575 ± 10%
Current (Amps)	350
Rated Speed	1172 RPM
Torque (lb ft)	1795 at rated speed
HP	400 at rated speed
Max. permissible speed	2340 RPM
Base motor weight	2,800 lbs.
Rotor weight	800 lbs
Recommended blower CFM	700
Nominal resistance / phase @ 25 °C	0.0139
Rotor balance	20.4 gram inches
Standard bearing grease	Mobil Unirex EP 2 *
Megger resistance	20 MΩ

\* Others available upon request.

## Dimensions

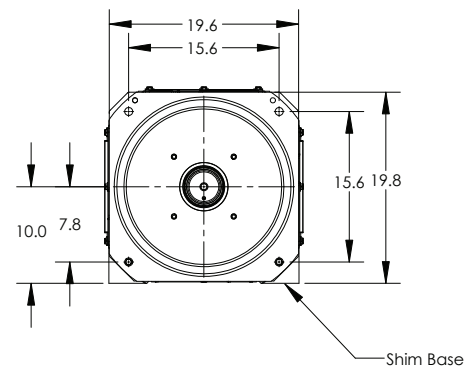
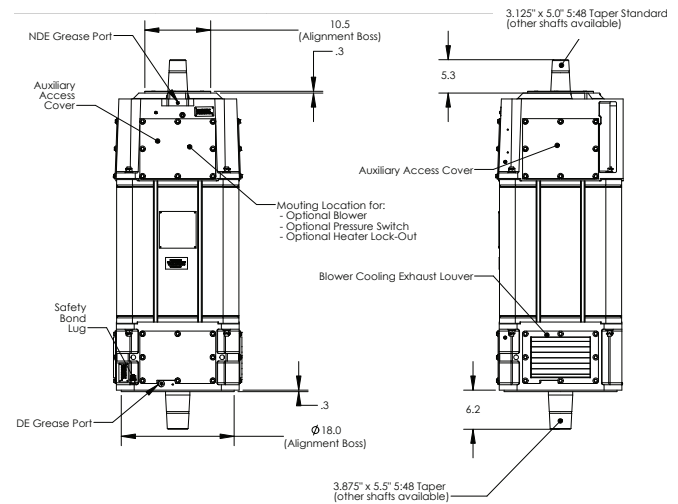

**Ward Leonard**  
 Excellence in Motor and Control Solutions™

Ward Leonard is a global provider of highly engineered motors, controls and integrated solutions that power Oil & Gas exploration. We provide benchmark performance, productivity, durability and customer support primarily for Top Drives, Mud Pumps, Draw Works, Rotary Tables, Engine Controls and Control Houses. Learn more at [www.wardleonard.com](http://www.wardleonard.com).

401 Watertown Road, Thomaston, CT 06787  
 P: 860.283.5801 | F: 860.283.5777 | [sales@wardleonard.com](mailto:sales@wardleonard.com) | [WardLeonard.com](http://WardLeonard.com)